



THE PARKS AT WALTER REED

PARCEL Z

Commission of Fine Arts
Concept Design Review

April 18, 2024

Project Team



PROJECT LOCATION

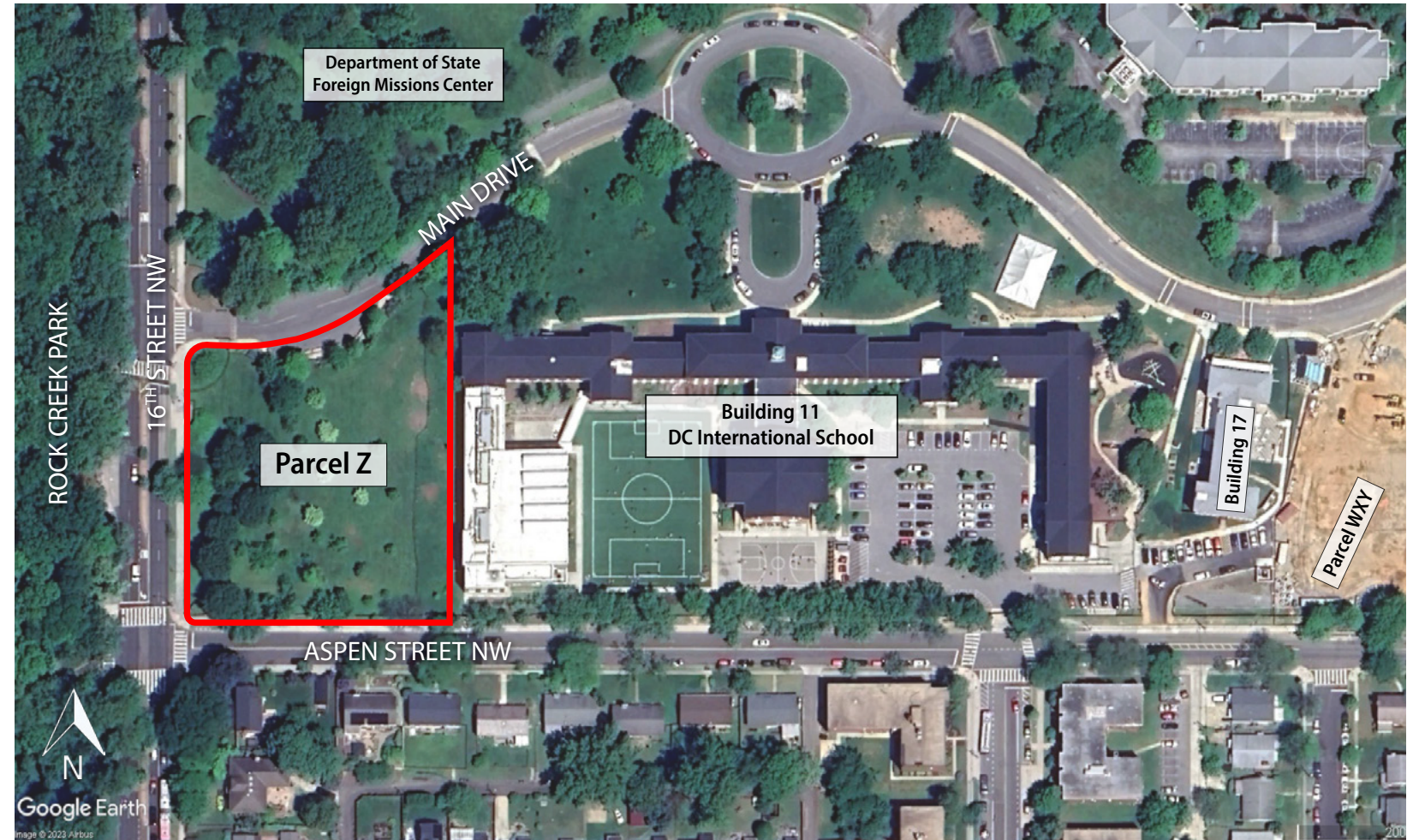
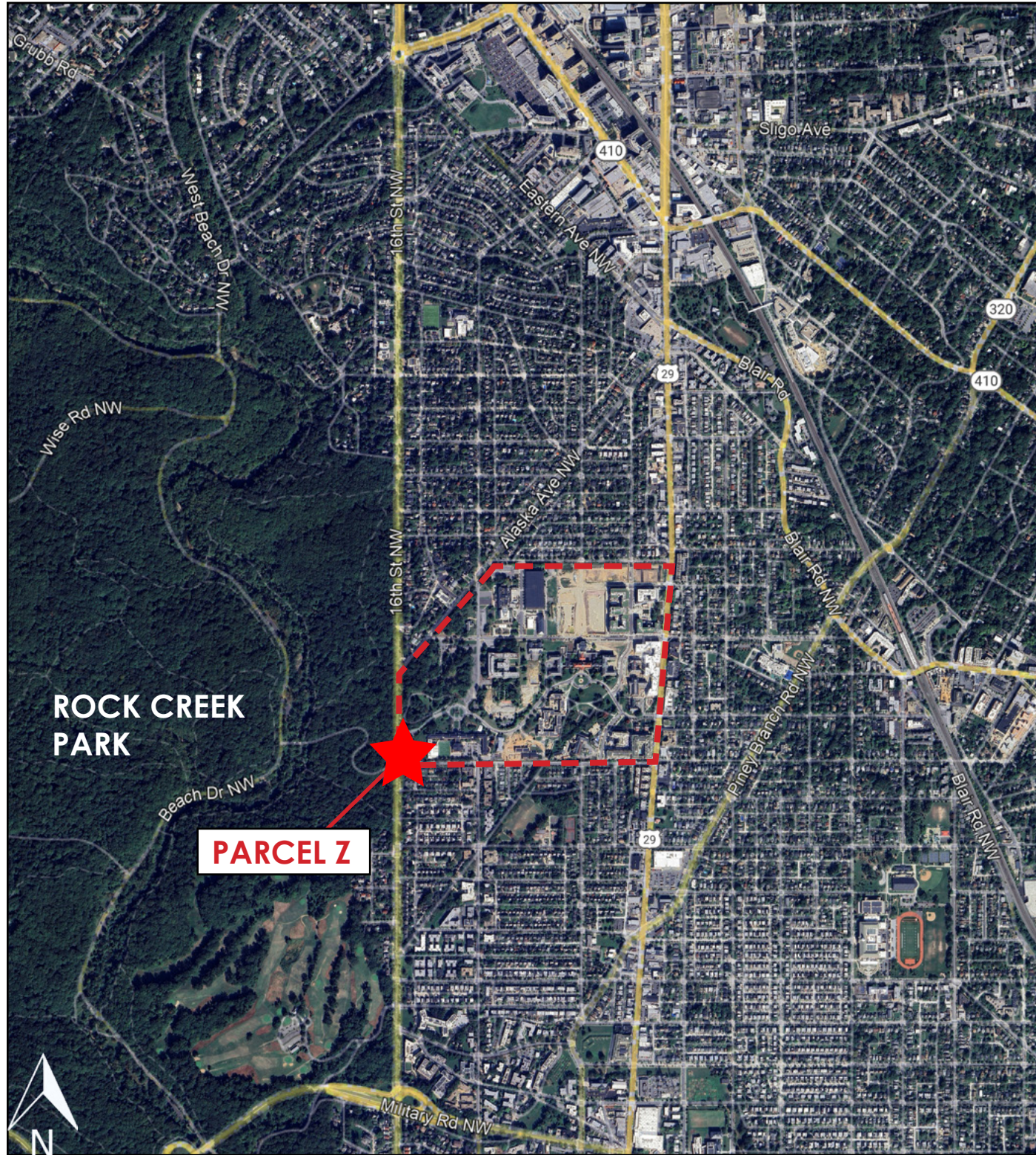

PROPOSED SITE PLAN AND LANDSCAPE PLAN

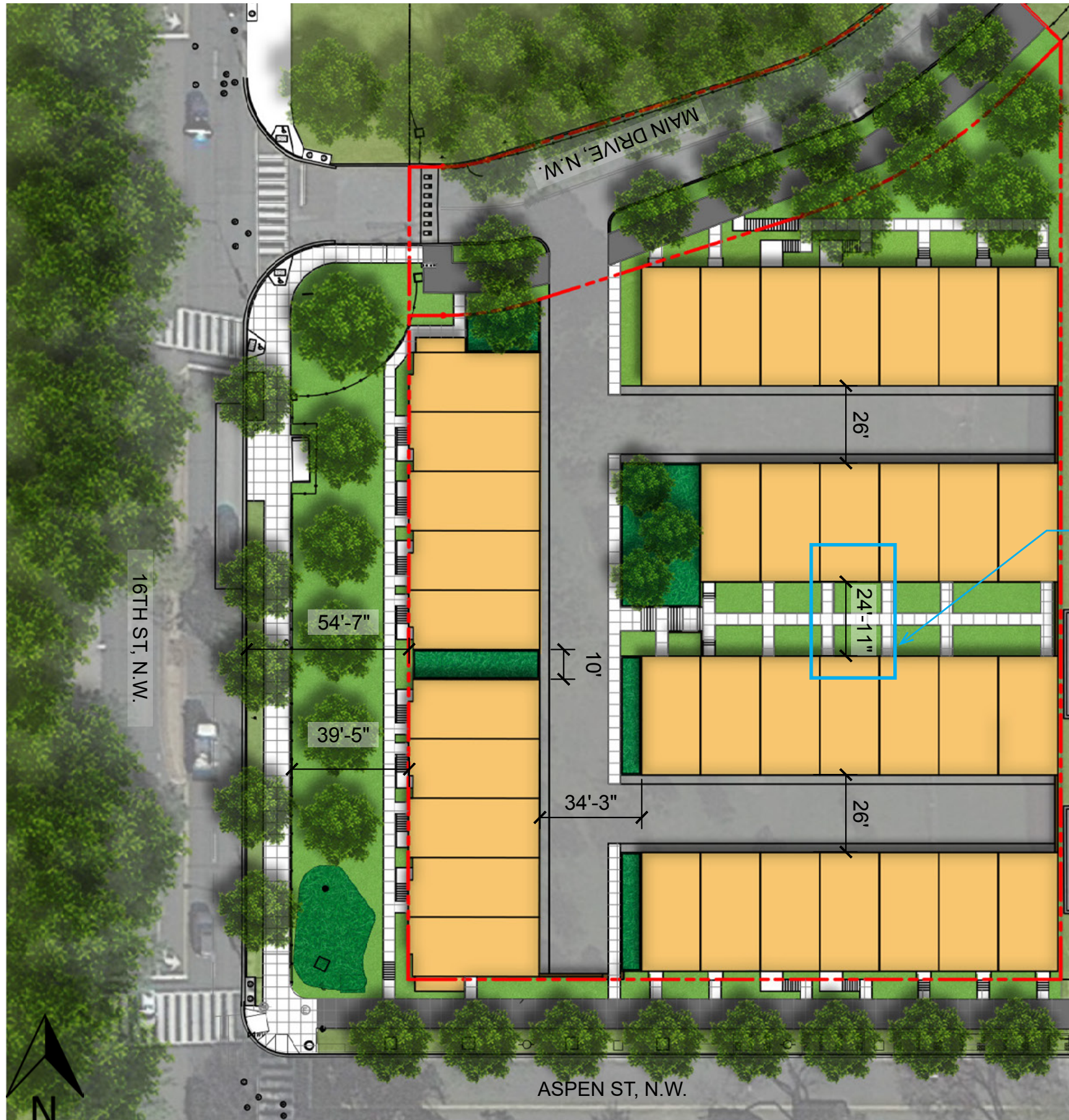

Legend

- Townhomes
- Planted Area
- Bioretention
- Concrete Sidewalks
- Asphalt Trail
- Roads

Proposed Trees



Landscape Planting



Bioretention Planting

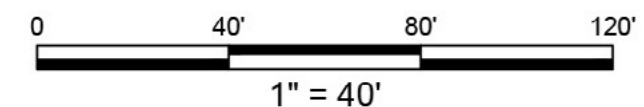

Width of mews increased

16TH STREET - FRONT ELEVATION (WEST)

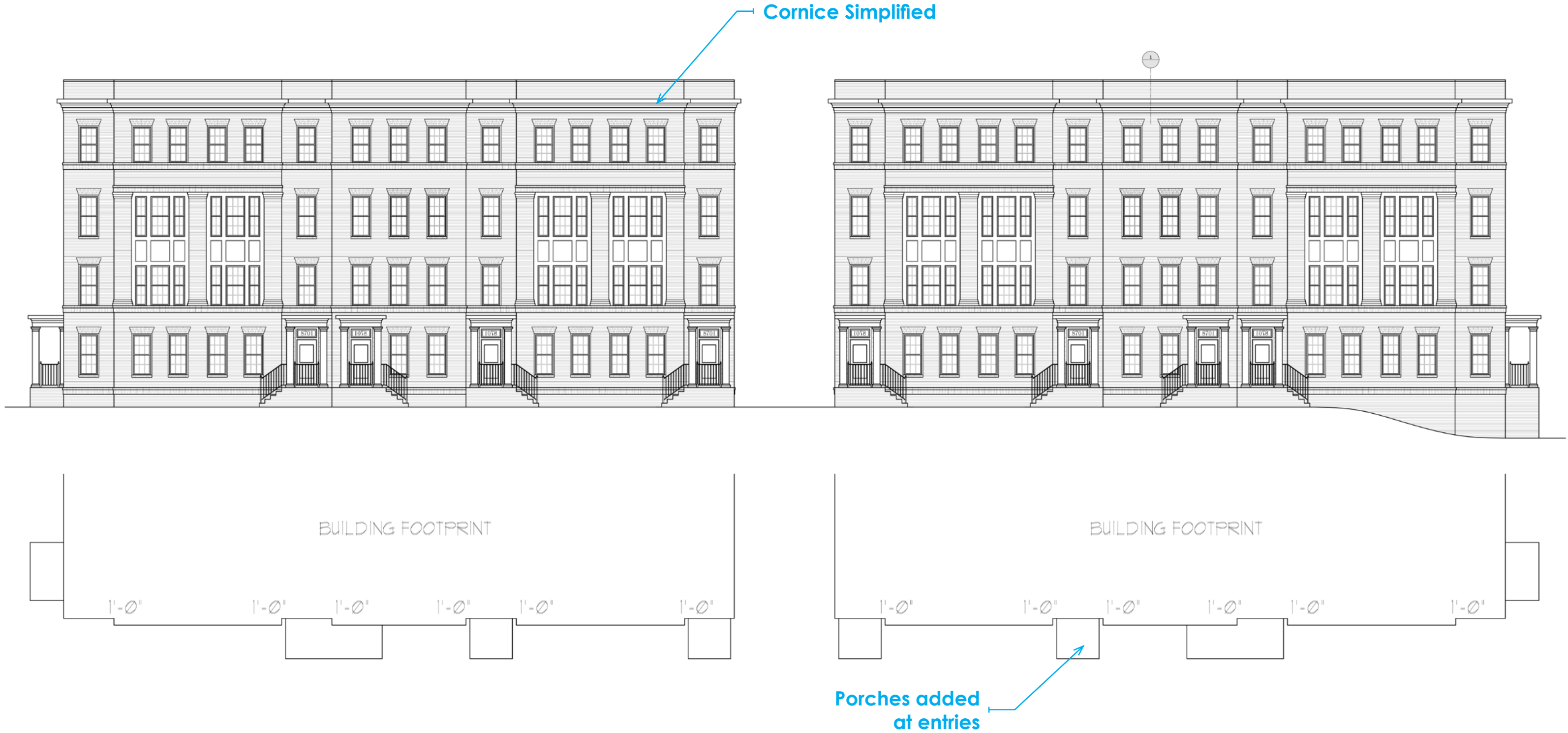

16TH STREET - REAR ELEVATION

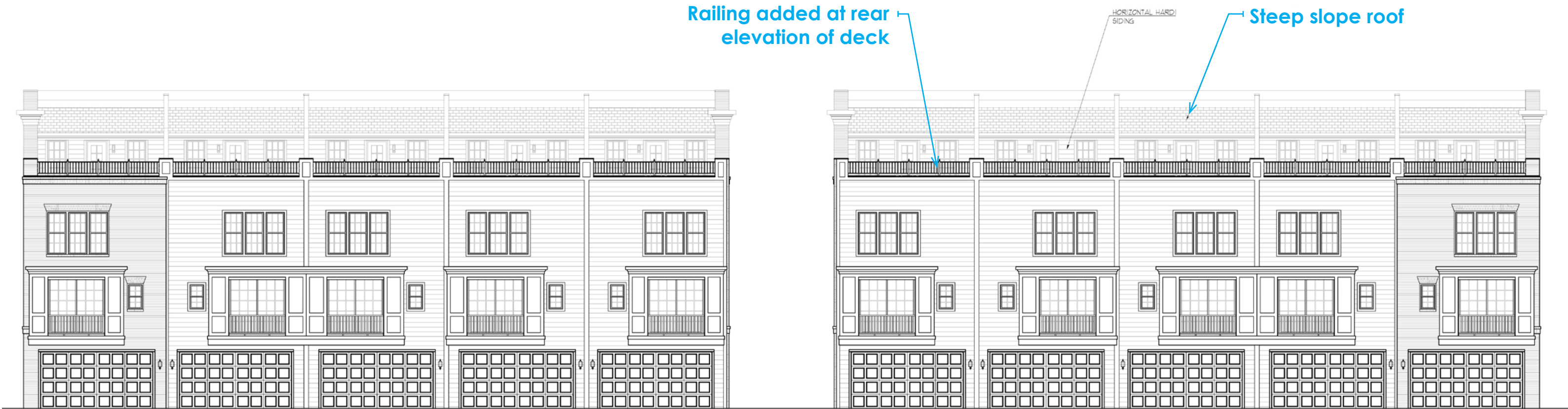

16TH STREET - SIDE ELEVATION AND LANAI DETAIL

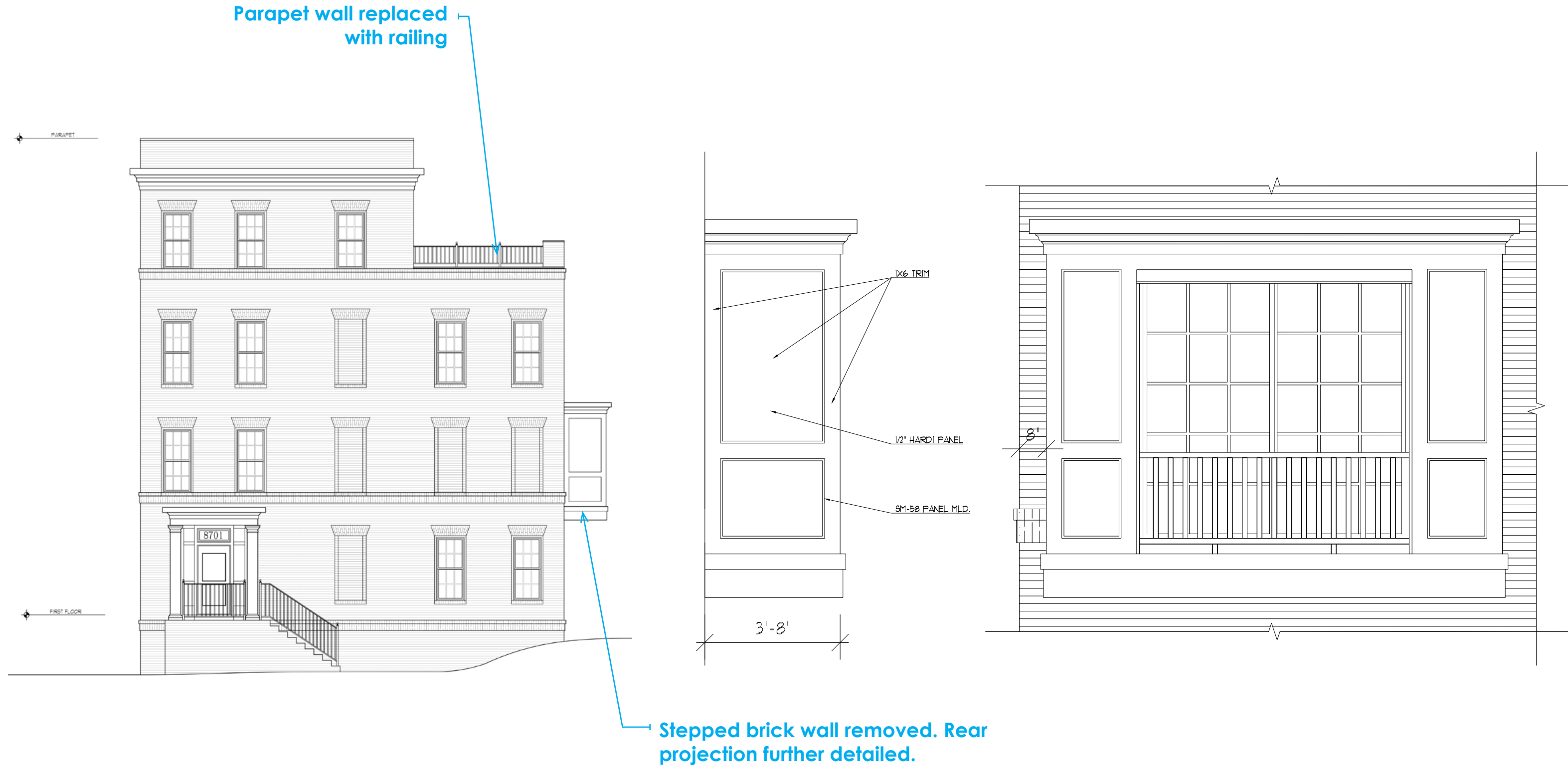

16TH STREET - REAR ELEVATION DETAIL



ASPEN STREET - FRONT ELEVATION (SOUTH)

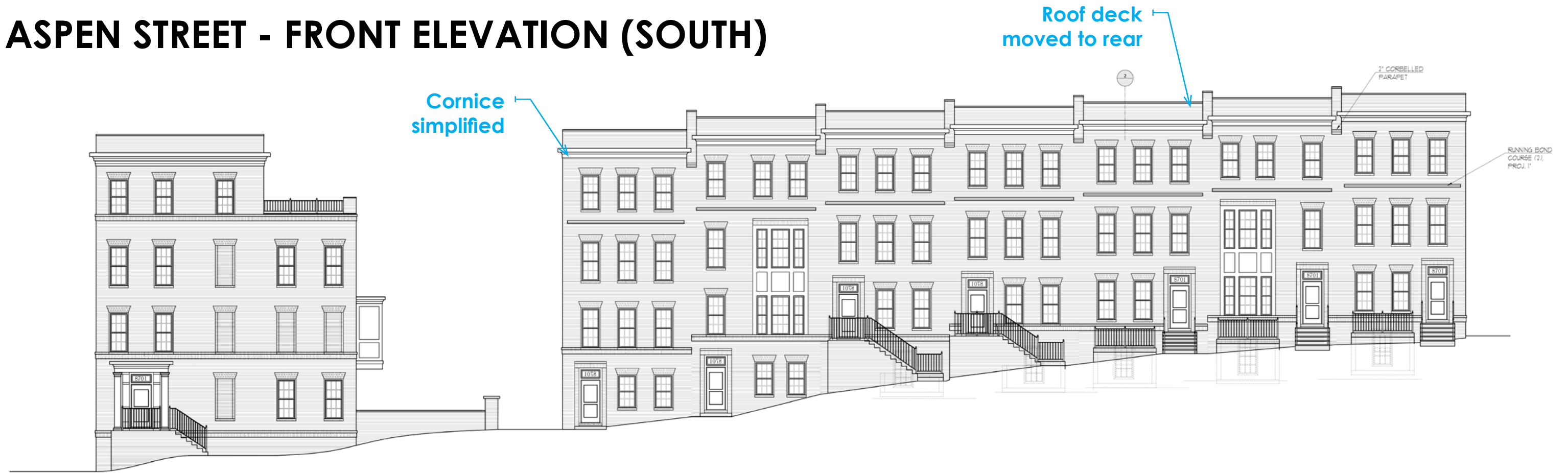

MAIN DRIVE - FRONT ELEVATION (NORTH)

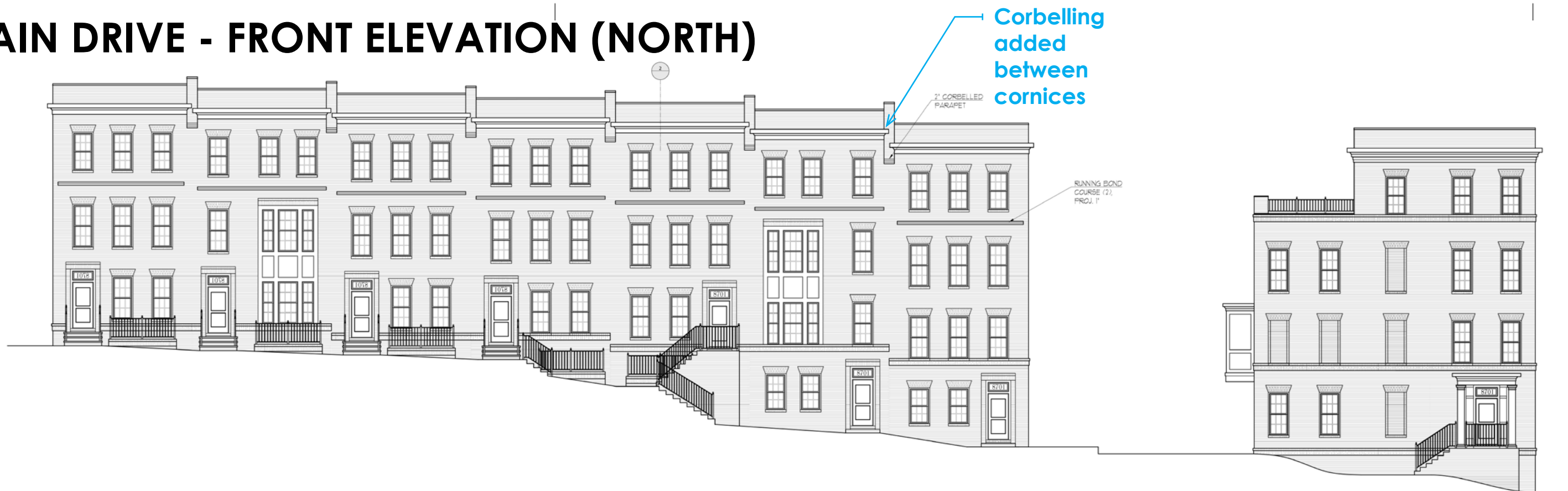

MEWS - FRONT ELEVATIONS



Alternative Option 1



Alternative Option 2



ASPEN STREET, MAIN DRIVE, AND MEWS - SIDE ELEVATIONS (PREFERRED)



MEWS - REAR ELEVATION



SITE SECTIONS



SITE SECTIONS



SITE SECTIONS

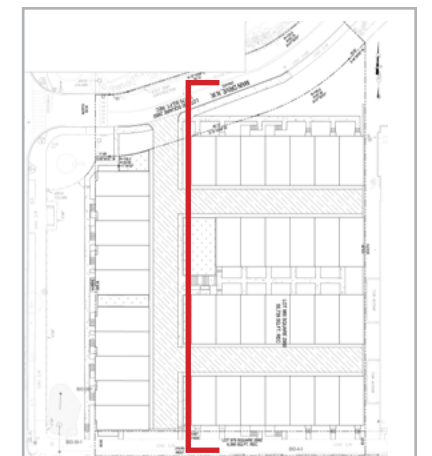
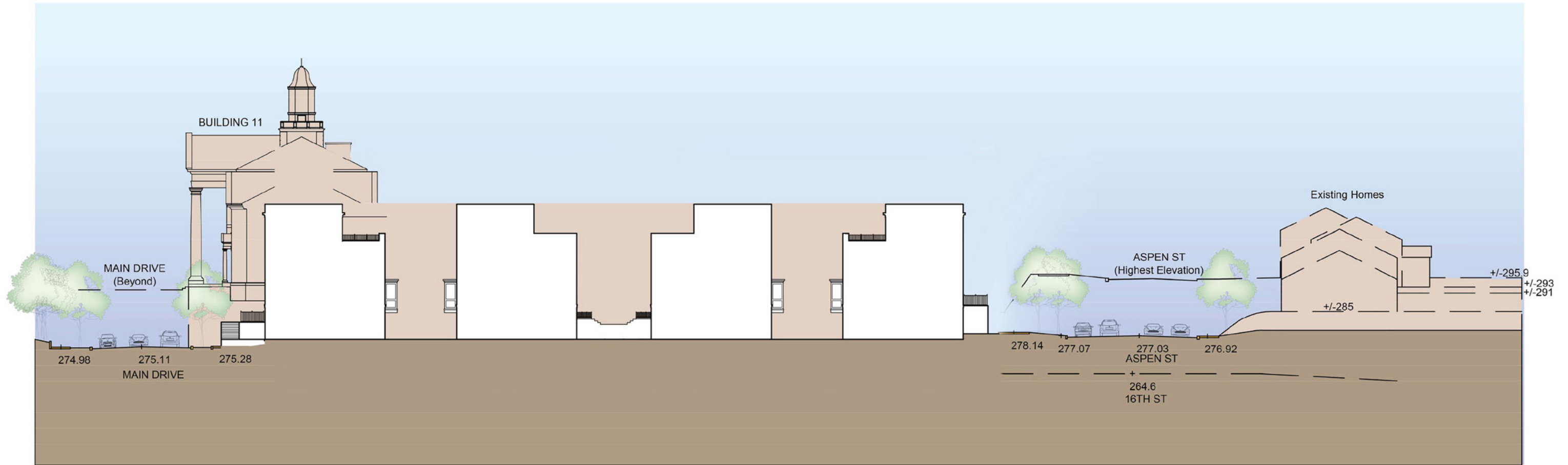

PROPOSED MATERIALS



Asphalt Shingle (steep slope roof)



Cementitious Lap Siding (Rear Elevations)

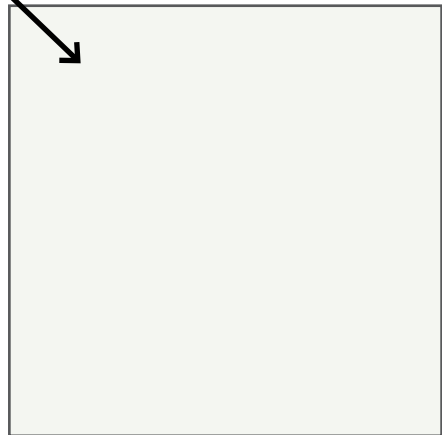

Trim and Panels - White



Ply Gem Mira Series Aluminum Clad Double Hung Window (White)

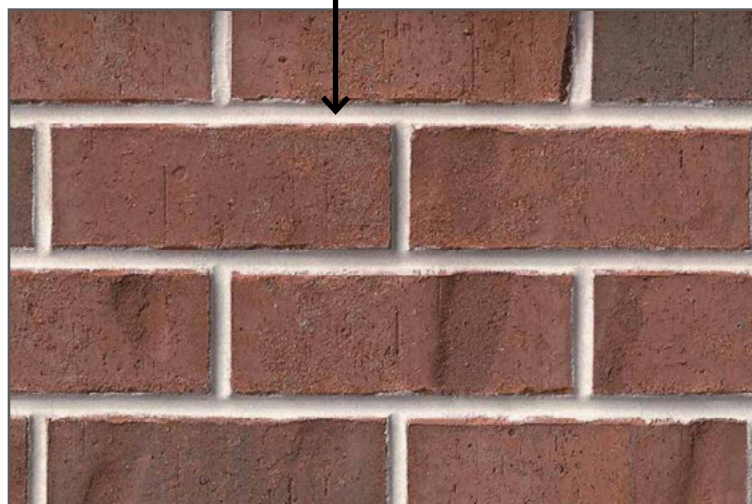

Brick color to be compatible with adjacent Building 11. Brick selection TBD.



Walter Reed Townhomes - Parcel WXY



Walter Reed Design Guidelines - Color Palette

CORNICE DETAILS



16th Street Cornice

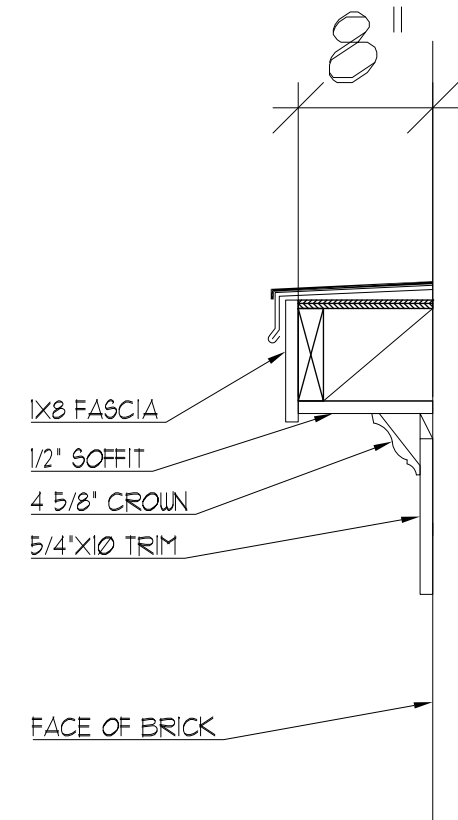
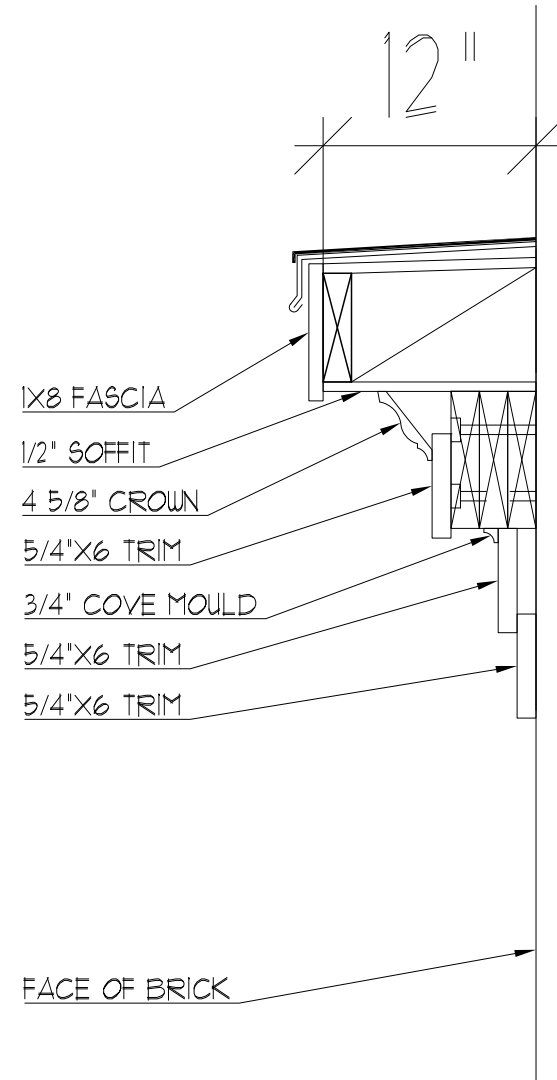

Mews Cornice

RENDERING - 16TH STREET AND MAIN DRIVE



RENDERING - ASPEN STREET



RENDERING - MAIN DRIVE

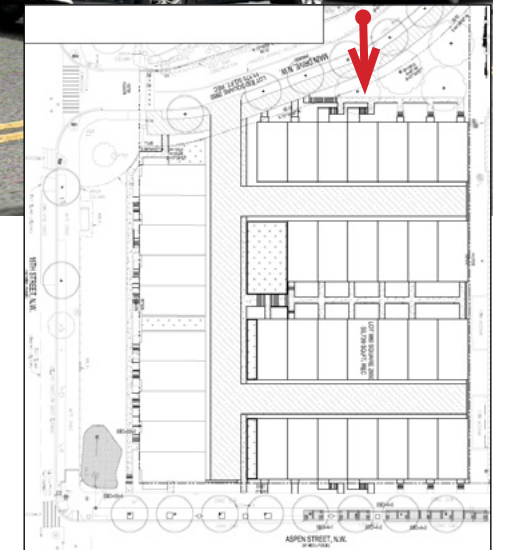

RENDERING - INTERNAL VIEW LOOKING NORTH



RENDERING - INTERNAL VIEW LOOKING SOUTH

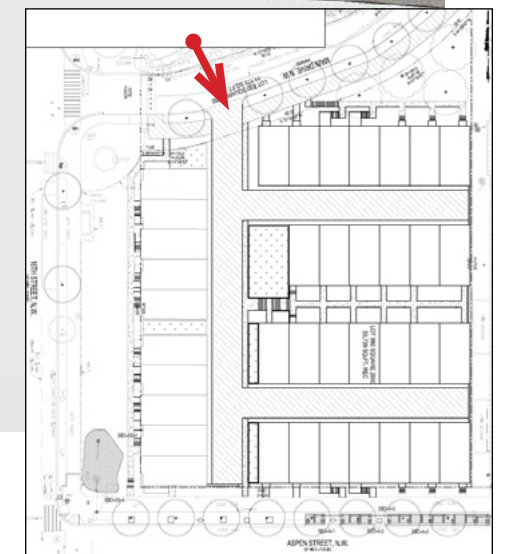

RENDERING - MEWS

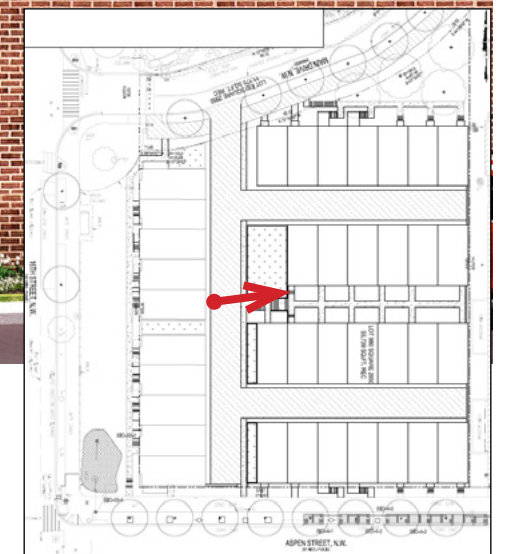

THANK YOU



PROPOSED SITE PLAN

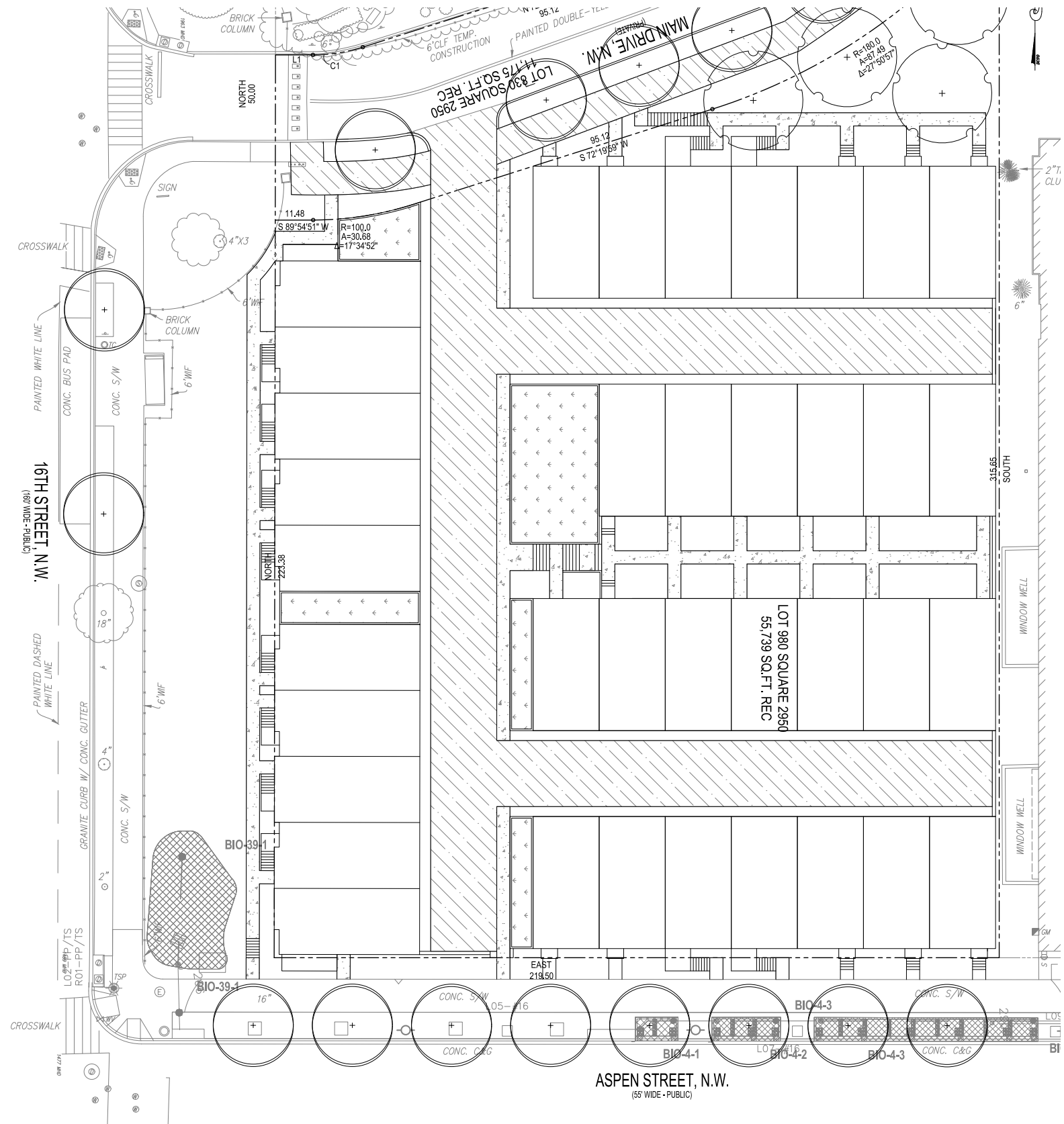

16TH STREET - SIDE ELEVATION AND LANAI DETAIL OPTIONS

Preferred Option



Alternative (Previous Proposal)



MAIN DRIVE AND ASPEN STREET - REAR ELEVATION



MEWS- FRONT ELEVATIONS (PREFERRED)

STEEP SLOPE ROOF
(ASPHALT, SEE 3D
IMAGE)



BUILDING FOOTPRINT

MEWS - SIDE ELEVATION CORNICHE OPTIONS

Preferred Option



Alternative Option 1



Alternative Option 2

